

Miniaturized Laser Speckle Reducer OEM Series

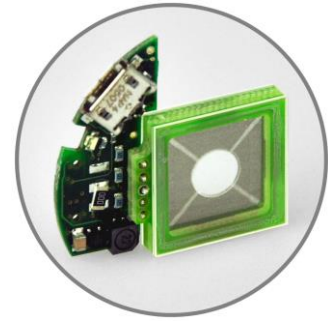

Speckle noise from a laser-based system is reduced by dynamically diffusing the laser beam. A diffuser is bonded to a thin elastic membrane, which includes four independent electro-active polymer electrodes that induce a circular oscillation of the diffuser in x- and y-direction. The OEM Series provides a minimal housing for easy integration and can be supplied with or without control electronics. Two sizes are available: the LSR-5-17 and the LSR-10-22 exhibiting a clear aperture of 5 mm and 10 mm, respectively.

Mechanical specifications

	LSR-5-17	LSR-10-22	
Clear aperture	5	10	mm
External dimensions (WxHxD)	17x17x3.8	22x22x3.8	mm
Weight (LSR only / including electronics)	1.44/2.50	2.18/3.24	g

Electrical specifications

Power supply (micro-USB interface) ¹	5	5	VDC
Power consumption (with std. electronics) ¹	310	310	mW
Electrode capacitance	75	120	pF

Optical specifications

Diffusion angle (FWHM)	6°/12°/17°/24°	6°/12°/17°/24°	
Transmission spectrum ²	see figures 2&3	see figures 2&3	
Damage threshold	>300	>300	W/cm ²
Oscillation frequency	~300	~180	Hz
Oscillation amplitude (peak to peak)	~300	~400	µm

Environmental specifications

Storage temperature	[-40,+85]	[-40,+85]	°C
Operating temperature	[-30,+85]	[-30,+85]	°C
Lifetime in operation ²	2000	2000	h

Figure 1 (a-c) show the effect of the LSR-5-17 on a laser spot ($\lambda = 650 \text{ nm}$, $P = 5 \text{ mW}$):

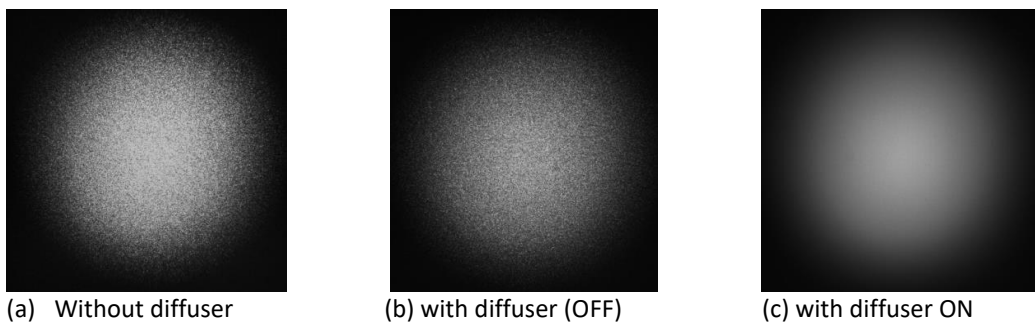

Figure 1: CCD images of a laser spot without and with LSR-5-17 on.

Attention: Do NOT use pressurized air to clean the LSR as this might cause the oscillating diffuser to irrevocably stick to the cover glass.

¹ 100-230 VAC to 5 VDC micro-USB power supply available.

² This product is ideal for applications with a low duty cycle. For applications with long lifetime Optotune's reluctance force LSR products are recommended

The following two figures show the transmission spectrum of the LSR-OEM series with polymer diffusers and coated BK7 cover glasses. The LSR-OEM-xxD series include both a static and an oscillating diffuser for increased speckle reduction efficiency. Only an oscillating diffuser and no static diffuser are present in the LSR-OEM-xxS series.

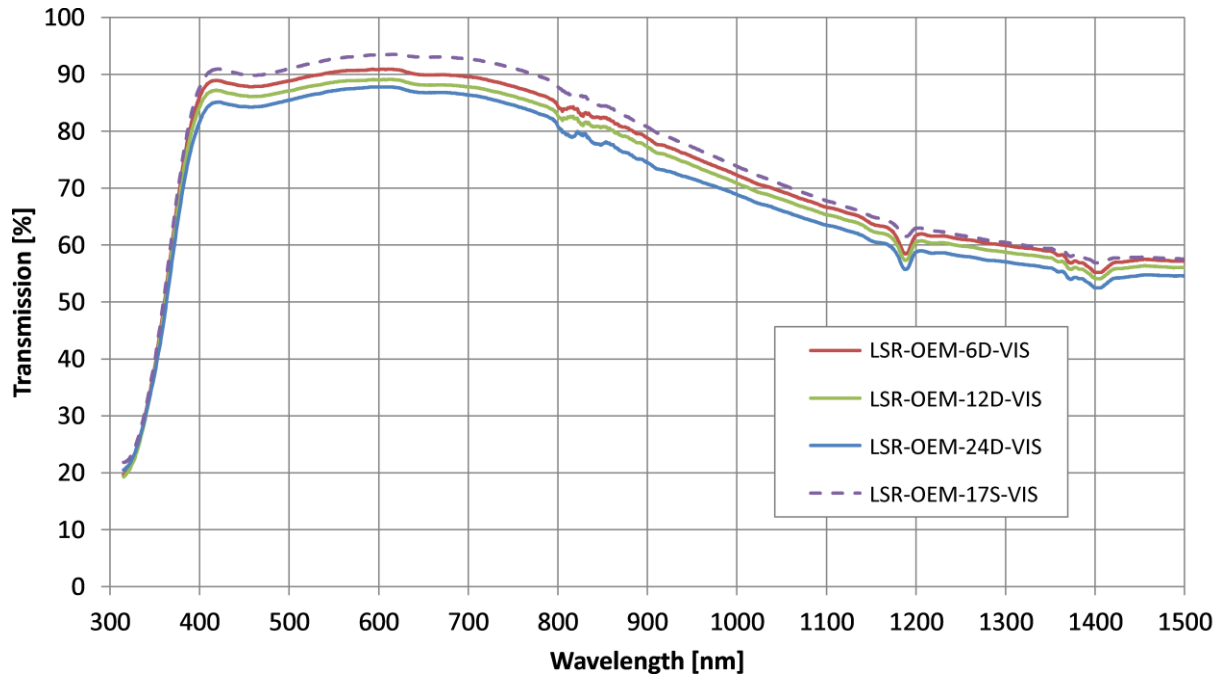

Figure 2: Transmission spectrum of the LSR-OEM series with VIS-coated cover glasses (0° angle of incidence)

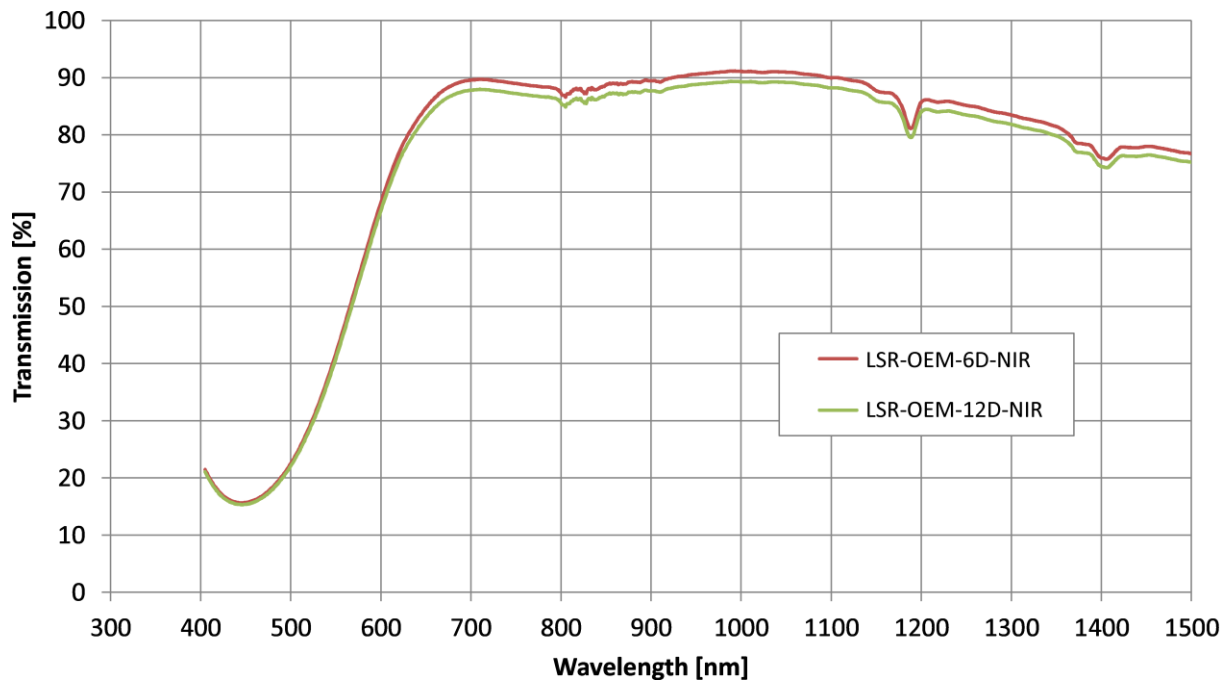

Figure 3: Transmission spectrum of the LSR-OEM series with NIR-coated cover glasses (0° angle of incidence)

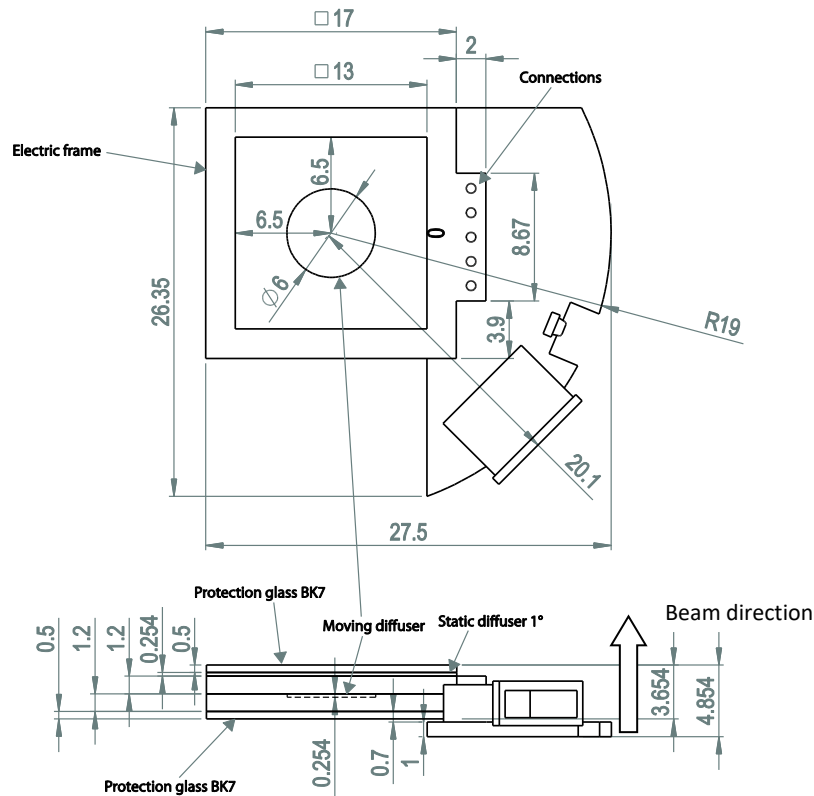

Figure 4: Overview of LSR-5-17- θ -AR-E including drive electronics (unit: mm). For detailed drawings, please contact sales@optotune.com

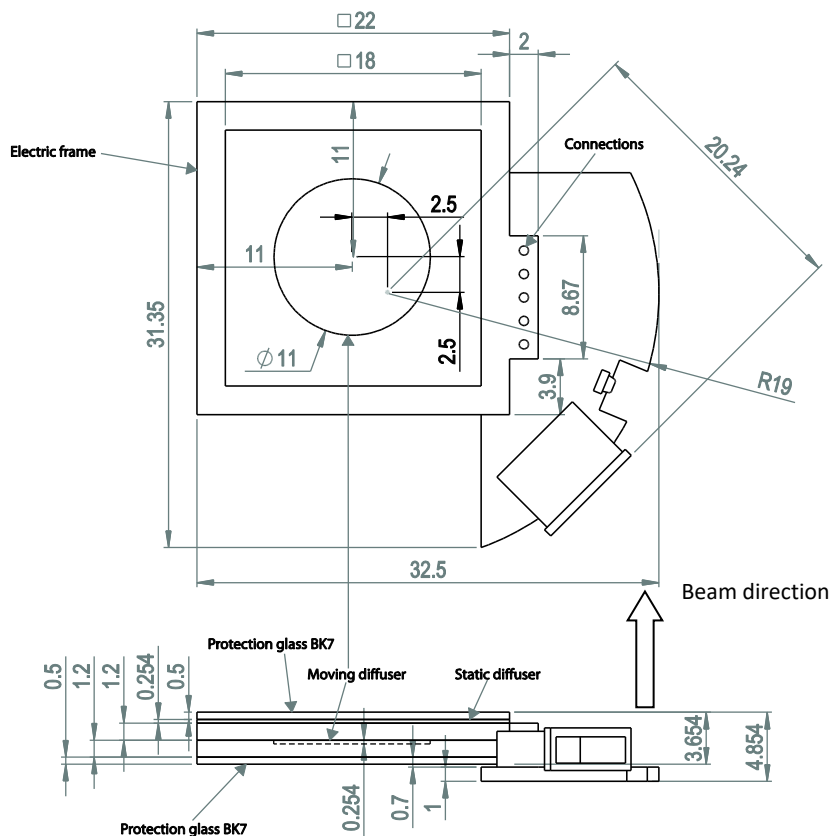

Figure 5: Overview of LSR-10-22- θ -AR-E including drive electronics (unit: mm). For detailed drawings, please contact sales@optotune.com.

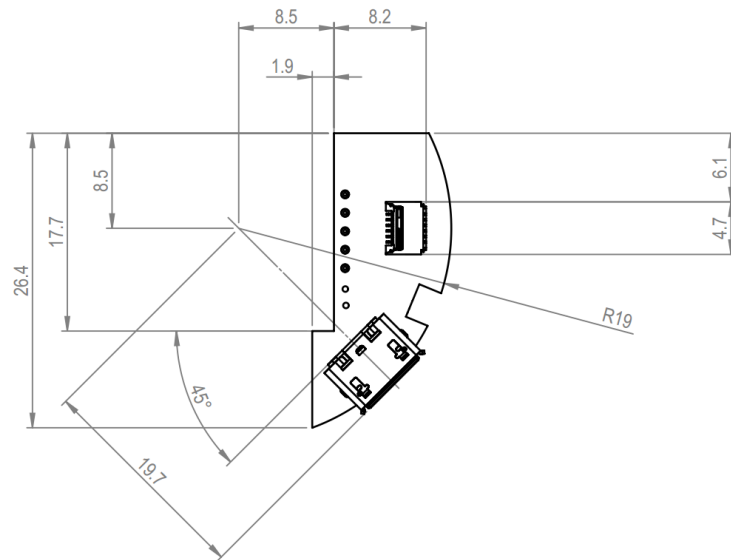

Figure 6: Mechanical drawing of electronics board (unit: mm). For detailed drawings, please contact sales@optotune.com.

Mounting

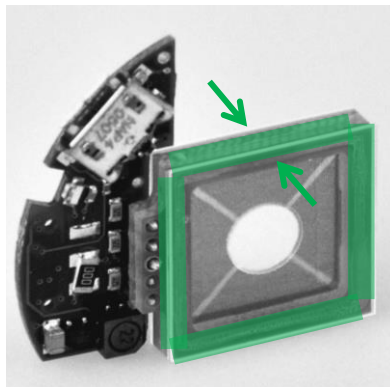

Figure 7: Recommended mounting. The frame of the LSR should be clamped in the beam direction by a soft material (e.g. o-ring). For detailed mounting instructions, please contact sales@optotune.com.



Warning: The LSR-5-17 and LSR-10-22 must not be clamped in the transverse direction, as this would lead to shear force on the different layers of the sandwich structure.

Electrical schematic

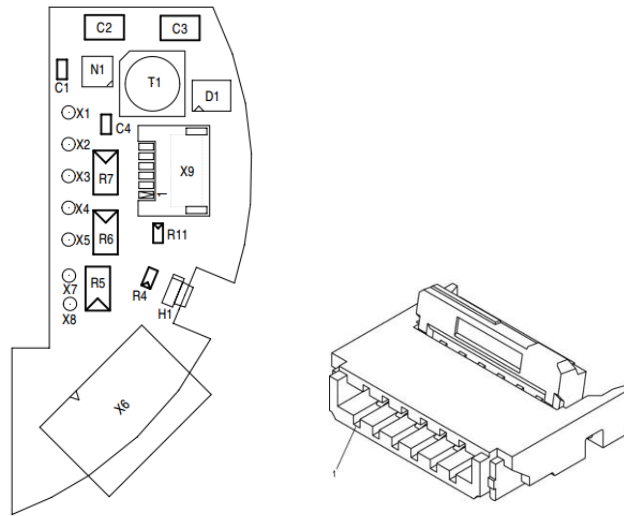

Figure 8: Left: schematic diagram of the LSR – OEM. Right: 6-pin flex connector (X9 in left panel). For detailed drawings, please contact sales@optotune.com.

The LSR-OEM is connected to the PCB via pins X1 to X5, see Figure 8. The power supply of the LSR-OEM is a micro-USB connector depicted as X6 in Figure 8. Instead of using the USB connector, the LSR-OEM can be directly driven by a voltage source using pin X7 (GND) and X8 (3.3V ... 5V).

Position	Function
1	VCC (+3.3V...5V)
2	RST
3	MISO / PB1
4	MOSI / PB0
5	GND
6	SCK / PB2

Table 1: Overview of pin configuration of Flex connector X9.

The pin configuration of the connector (X9, FPC Molex 503480-0600) is defined in Table 1. The connector is used to program the LSR.

Lifetime

The LSR has passed the following accelerated aging tests. The tests were performed on 5-10 samples each and are considered as passed if the oscillation amplitude of all samples did not change more than 5%.

Test	LSR-5-17
A1 – High temperature (operating): <ul style="list-style-type: none"> Test temperature: 85°C ±5°C Test duration: 48 hours Reference: JESD22-A108-B, JESD47-A and JESD74 	Passed
A2 – Low temperature (operating): <ul style="list-style-type: none"> Test temperature: -30°C ±5°C Test duration: 48 hours Reference: JESD22-A108-B, JESD47-A 	Passed
A3.1 – Temperature cycling (non-operating): <ul style="list-style-type: none"> Low temperature: -40°C, high temperature: +85°C Transition time: <3 minutes Test duration: 30 min for each under low and high temperature Number of cycles: 100 cycles Recovery time: 2 hours References: IEC 60068-2-1, IEC 60068-2-2 and IEC 60068-2-14 	Passed
A3.2 – Damp heat cycling (non-operating): <ul style="list-style-type: none"> Low temperature: 25°C, high temperature: +55°C Test humidity: 90-100% relative humidity Test duration: 12 hours dwell Temperature change rate: Less than 1°C per minute Number of cycles: 18 cycles Recovery time: No recovery time References: IEC 60068-2-30 Db Variant 1 	Passed
A4 – High temperature (non-operating): <ul style="list-style-type: none"> Test temperature: Static 85°C ±2°C Test humidity: Less than 20 g/m³ of water vapor (corresponding to approximately 50% relative humidity at 35 °C) Test duration: 168 hours Temperature change rate: Less than 1°C per minute Reference: IEC 60068-2-2 Bb 	Passed
Shock test: <ul style="list-style-type: none"> 400 g for 1 ms duration 5 pulses in each direction (30 pulses in total) 	Passed
Operating lifetime test: <ul style="list-style-type: none"> Test temperature: 22 ±2°C Test duration: 2000 hours Driving frequency: 300 Hz 	Passed ³

Table 2: Environmental and accelerated aging tests performed on the LSR Series.

³ The average amplitude of 300um dropped to 200um after 2000 hours of operation.

Ordering information for standard diffusion angles

The LSR-OEM is currently available with two aperture and frame sizes, different diffusing angles (circular) and two types of cover glasses. When ordering, please refer to these specifications as follows:

LSR-A-S- θ N-AR-E

- A = Clear aperture in mm (5 or 10)
- S = Frame size in mm (17 or 22)
- θ = Total diffusion angle (6°, 12°, 17°, 24° available as standard)
- N = Diffuser configuration, whereas D = double (one oscillating, one static), S = single (one oscillating only)
- AR = Antireflection coating (VIS or NIR)
- E = Including drive electronics (optional)

Examples: LSR-5-17-17S-VIS-E refers to a speckle reducer with a clear aperture of 5 mm, a frame size of 17 mm, a total diffusing angle of 17°, with an oscillating diffuser only, VIS coated cover glasses and ships with the drive electronics attached.

LSR-10-22-6D-NIR refers to a speckle reducer with a clear aperture of 10 mm, a frame size of 22 mm, a total diffusing angle of 6°, with both an oscillating and a static diffuser, NIR coated cover glasses and ships without any electronics.

Standard models with different diffuser combinations

The standard models combine an oscillating diffuser with a static diffuser to reduce the correlation length of the random patterns that are generated. This provides more effective speckle reduction yet minimizing the increase in beam divergence. Three standard diffuser configurations are available: LSR-OEM-xxD series with 6° (FWHM) for highest optical efficiency and 24° for best speckle reduction. For optical systems where the spot on the LSR is imaged by e.g. a 4f-system, no static diffuser is allowed. In that case, the LSR-OEM-xxS series with an oscillating diffuser only is recommended.

Standard products	Clear aperture	Total diffusion angle	Diffuser configuration	Cover glass coating
LSR-5-17-6D-VIS	5 mm	6°	4.2° oscillating, 4.2° static	400 – 700 nm
LSR-5-17-12D-VIS	5 mm	12°	8.5° oscillating, 8.5° static	400 – 700 nm
LSR-5-17-24D-VIS	5 mm	24°	17° oscillating, 17° static	400 – 700 nm
LSR-5-17-17S-VIS	5 mm	17°	17° oscillating, no static	400 – 700 nm
LSR-5-17-6D-NIR	5 mm	6°	4.2° oscillating, 4.2° static	700 – 1100 nm
LSR-5-17-12D-NIR	5 mm	12°	8.5° oscillating, 8.5° static	700 – 1100 nm
LSR-10-22-6D-VIS	10 mm	6°	4.2° oscillating, 4.2° static	400 – 700 nm
LSR-10-22-12D-VIS	10 mm	12°	8.5° oscillating, 8.5° static	400 – 700 nm

Table 3: Overview of standard LSR-OEM models.

The diffuser angle is defined as full width half maximum (FWHM)

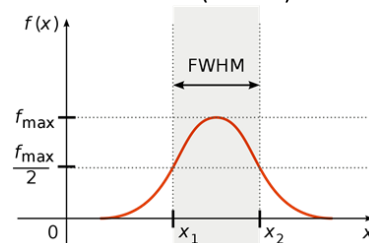

Custom products

Optotune offers customized versions of the LSR. This datasheet only contains variations of the LSR-OEM series products. For LSRs with substantially smaller or larger apertures, please contact sales@optotune.com.

Diffusers

In principle, any type of diffuser can be used as long as size and weight are similar to the standard diffuser. Furthermore, it is possible to use specialty coated glass diffusers if they are light enough. If necessary, it is also possible to remove the membrane from the optical path.

The following table summarizes these options:

Diffuser type	Optotune polymer	Glass diffusers (typical)
Thickness	330 μm	As thin as possible
Density	1.03 g/cm^3	2.2 g/cm^3
Weight		
5 mm aperture ⁴	9 mg	up to 20 mg
10 mm aperture	30 mg	up to 70 mg
Resonance frequency		$\omega \propto \sqrt{\frac{1}{m}}$
5 mm aperture	300 Hz	
10 mm aperture	180 Hz	
Transmission range	240 – 2500 nm	170 – 12000 nm (depending on material)
Damage threshold	> 300 W/cm^2	1 kW/cm^2 (depending on material)

Please note that diffusers cannot be exchanged after the LSR has been produced. Also, when using customized diffusers it might be necessary to select an appropriate cover glass to match the transmission range.

Cover glasses

Cover glasses can be customized with respect to material and antireflection coating. The standard cover glasses are VIS or NIR coated BK7. If the LSR is to be integrated into a clean environment, then the cover glasses can be omitted.

Frequency

The oscillation frequency is set to the measured mechanical resonant frequency of the LSR during production. With the current standard electronics, it is not possible to change that frequency after production.

Safety and compliance

The product fulfills the RoHS and REACH compliance standards. The product is delivered without housing. The customer is solely responsible to comply with all relevant safety regulations for integration and operation.

For more information on optical, mechanical and electrical parameters, please contact sales@optotune.com.

⁴ Note: The 5mm and 10mm aperture LSR is usually equipped with 6mm and 11mm diameter diffuser, respectively.